

SPEED CONTROL & BRAKE MOTORS

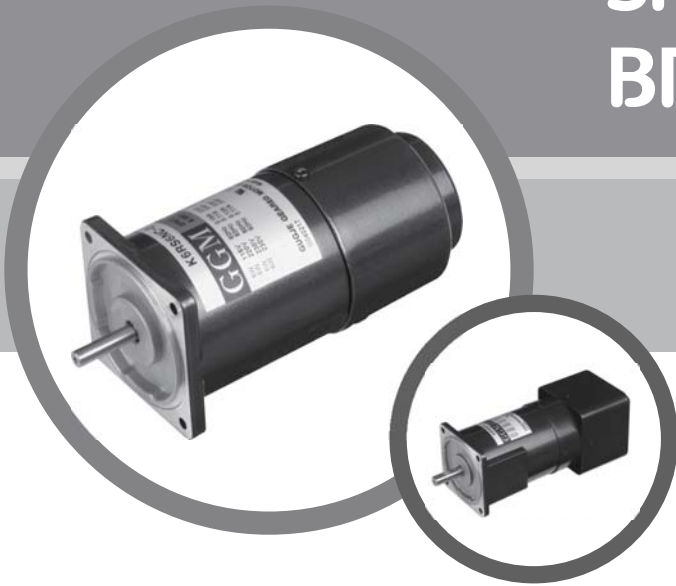

SPEED CONTROL & BRAKE MOTOR

6W

□60mm

K6RS6N□-D

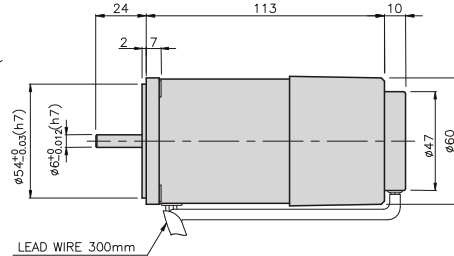
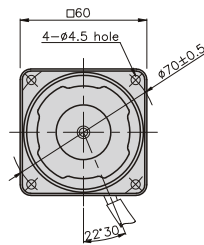

SPECIFICATIONS

6W 30 minutes rating, four poles

Model	Voltage (V)	Frequency (Hz)	Speed Range (rpm)	Permissible Torque		Start T. (N*m/Kgf*cm)	Current (A)	Condenser (μF)	Friction T. (N*m/Kgf*cm)
				1200rpm (N*m/Kgf*cm)	90rpm (N*m/Kgf*cm)				
K6R□6NJ-D	100	50	90 ~ 1400	0.052/0.52	0.035/0.35	0.027/0.27	0.28	3	0.2/2
			90 ~ 1700						
K6R□6NU-D	110	60	90 ~ 1700	0.052/0.52	0.035/0.35	0.035/0.35	0.32	2.5	0.2/2
	115								
K6R□6NL-D	200	50	90 ~ 1400	0.06/0.6	0.038/0.38	0.037/0.37	0.2	1	0.2/2
			90 ~ 1700						
K6R□6NC-D	220	50	90 ~ 1400	0.052/0.52	0.03/0.3	0.035/0.35	0.2	0.8	0.2/2
			90 ~ 1700			0.033/0.33			
	230	50	90 ~ 1400	0.06/0.6	0.038/0.38	0.035/0.35			
			90 ~ 1700			0.033/0.33			
K6R□6ND-D	240	50	90 ~ 1400	0.052/0.52	0.03/0.3	0.035/0.35	0.6	0.2/2	

* □ : SHAFT SHAPE (S : STRAIGHT, G : PINION)

RATED TORQUE OF GEARHEAD

● Single-phase 100V/115V

unit = above : N · m / below : kgfcm

Model	Ratio	Speed(rpm)																								
		3	3.6	5	6	7.5	9	10	12.5	15	18	20	25	30	36	40	50	60	75	90	100	120	150	180	200	250
K6R□6N□-D K6G□B(C)	1200	0.13 1.3	0.15 1.5	0.21 2.1	0.25 2.5	0.32 3.2	0.38 3.8	0.42 4.2	0.53 5.3	0.63 6.3	0.76 7.6	0.76 7.6	0.95 9.5	1.14 11.4	1.36 13.6	1.52 15.2	1.71 17.1	2.05 20.5	2.56 25.6	3 30	3 30	3 30	3 30	3 30	3 30	3 30
	90	0.09 0.9	0.10 1.0	0.14 1.4	0.17 1.7	0.21 2.1	0.26 2.6	0.28 2.8	0.35 3.5	0.43 4.3	0.51 5.1	0.51 5.1	0.64 6.4	0.77 7.7	0.92 9.2	1.02 10.2	1.15 11.5	1.38 13.8	1.72 17.2	2.07 20.7	2.30 23.0	2.76 27.6	3 30	3 30	3 30	3 30

● Single-phase 200V/240V

unit = above : N · m / below : kgfcm

Model	Ratio	Speed(rpm)																									
		3	3.6	5	6	7.5	9	10	12.5	15	18	20	25	30	36	40	50	60	75	90	100	120	150	180	200	250	
K6R□6N□-D K6G□B(C)	1200	200V/230V 50Hz/60Hz	0.15 1.5	0.17 1.7	0.24 2.4	0.29 2.9	0.36 3.6	0.44 4.4	0.49 4.9	0.61 6.1	0.73 7.3	0.87 8.7	0.87 8.7	1.09 10.9	1.31 13.1	1.57 15.7	1.75 17.5	1.97 19.7	2.36 23.6	2.95 29.5	3 30	3 30	3 30	3 30	3 30	3 30	3 30
		220V/150Hz/60Hz 240V/50Hz	0.13 1.3	0.15 1.5	0.21 2.1	0.25 2.5	0.32 3.2	0.38 3.8	0.42 4.2	0.53 5.3	0.63 6.3	0.76 7.6	0.76 7.6	0.95 9.5	1.14 11.4	1.36 13.6	1.52 15.2	1.71 17.1	2.05 20.5	2.56 25.6	3 30	3 30	3 30	3 30	3 30	3 30	3 30
	90	200V/230V 50Hz/60Hz	0.09 0.9	0.11 1.1	0.15 1.5	0.18 1.8	0.23 2.3	0.28 2.8	0.31 3.1	0.38 3.8	0.46 4.6	0.55 5.5	0.55 5.5	0.69 6.9	0.83 8.3	1.00 10.0	1.11 11.1	1.25 12.5	1.50 15.0	1.87 18.7	2.24 22.4	2.49 24.9	2.99 29.9	3 30	3 30	3 30	3 30
		220V/150Hz/60Hz 240V/50Hz	0.07 0.7	0.09 0.9	0.12 1.2	0.15 1.5	0.18 1.8	0.22 2.2	0.24 2.4	0.30 3.0	0.36 3.6	0.44 4.4	0.44 4.4	0.55 5.5	0.66 6.6	0.79 7.9	0.87 8.7	0.98 9.8	1.18 11.8	1.48 14.8	1.77 17.7	1.97 19.7	2.36 23.6	2.95 29.5	3 30	3 30	3 30

* Gearhead and decimal gearhead are sold separately.

* The code in □ of gearhead model is for gear ratio.

* ■ color indicates that the output shaft of the geared motor rotates in the same direction as the output shaft of the motor. Others indicate rotation in the opposite direction.

* If you are to have less ratio than the ratio in the table, you can install the decimal gearhead, which has one tenth of the ratio, between the gearhead and the motor. In this case, the permissible torque is 3N · m/30kgfcm.

* RPM is based on motor's synchronous rpm (50HZ:1500rpm, 60HZ:1800rpm) and calculated by dividing gear ratio. Actual rpm is 2~20% less than indicating rpm according to load size.

GEARHEADS

CONNECTION DIAGRAMS

Connect Cr circuit for absorbing surge voltage as connection diagram to protect contact point.
 $R_o = 5 - 200\Omega$
 $C_o = 0.1 \sim 0.2\mu F$ 200WV(400WV)

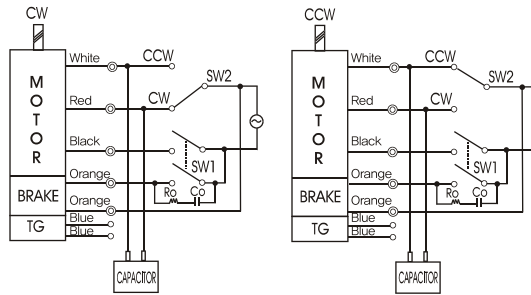

※The direction of motor rotation is as viewed from the front shaft end of the motor

DIMENSIONS

K6G□B(C)



K6RG6N□-D + K6G□B(C)



DECIMAL GEARHEAD

K6G10BX

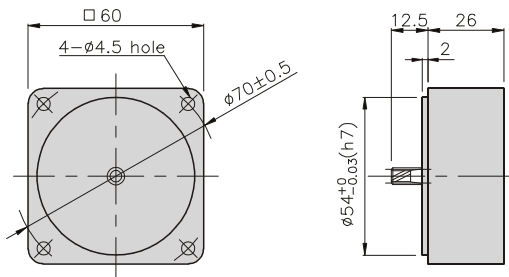

GEARHEAD

K6G□B(C)

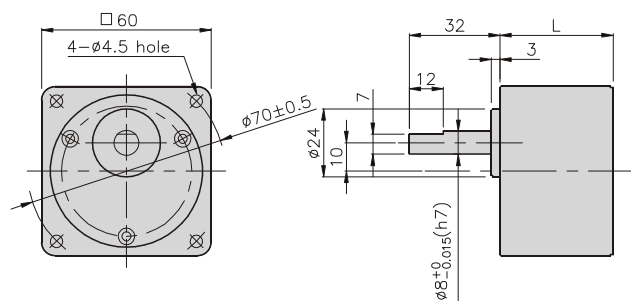

DIMENSION TABLE

PART No.	L	Application Model	Mounting BOLT
01	30	K6G3~18B(C)	M4 P0.7 X 50
02	40	K6G20~250B(C)	M4 P0.7 X 60
03	26	K6G10BX	M4 P0.7 X 85

WEIGHT

PART	WEIGHT(kg)	
MOTOR	1.00	
DECIMAL GEAR HEAD	0.22	
GEAR HEAD	K6G3~18B(C)	0.26
	K6G20~40B(C)	0.33
	K6G60~250B(C)	0.36

K6RG6N□-D + K6G□B(C)

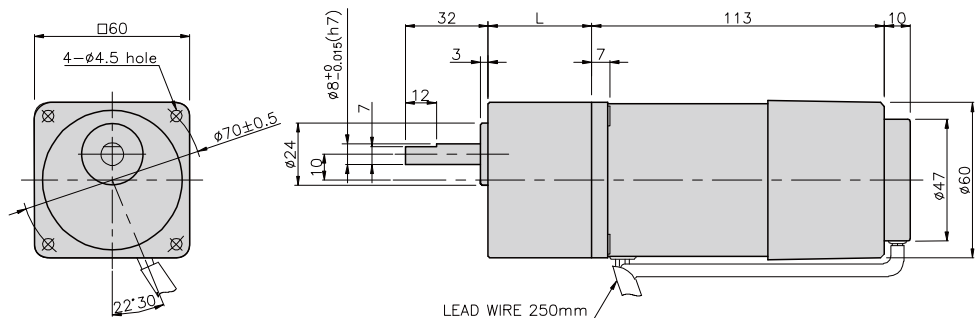

SPEED CONTROL & BRAKE MOTOR

15W

□70mm

K7RS15N□-D

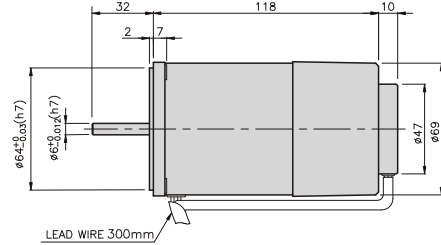
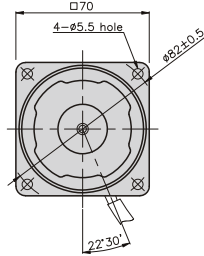

SPECIFICATIONS

15W 30 minutes rating, four poles

Model	Voltage (V)	Frequency (Hz)	Speed Range (rpm)	Permissible Torque		Start T. (N*m/ Kgf*cm)	Current (A)	Condenser (μF)	Friction T. (N*m/ Kgf*cm)
				1200rpm (N*m/ Kgf*cm)	90rpm (N*m/ Kgf*cm)				
K7R□15NJ-D	100	50	90 ~ 1400	0.14/1.4	0.05/0.5	0.085/0.85	0.56	7	0.2/2
		60	90 ~ 1700						
K7R□15NU-D	110	60	90 ~ 1700	0.14/1.4	0.05/0.5	0.085/0.85	0.58	6	0.2/2
	115								
K7R□15NL-D	200	50	90 ~ 1400	0.135/1.35	0.055/0.55	0.09/0.9	0.31	2	0.2/2
		60	90 ~ 1700	0.115/1.15					
K7R□15NC-D	220	50	90 ~ 1400	0.135/1.35	0.05/0.5	0.08/0.8	0.3	1.5	0.2/2
		60	90 ~ 1700	0.115/1.15					
	230	50	90 ~ 1400	0.135/1.35	0.055/0.55	0.085/0.85	0.3		
		60	90 ~ 1700	0.115/1.15					
K7R□15ND-D	240	50	90 ~ 1400	0.135/1.35	0.05/0.5	0.09/0.9	0.34	1.5	0.2/2

* □ : SHAFT SHAPE (S : STRAIGHT, G : PINION)

RATED TORQUE OF GEARHEAD

● Single-phase 100V/115V

unit = above : N · m / below : kgfcm

Model	Ratio	Speed (rpm)																							
		3	3.6	5	6	7.5	9	10	12.5	15	18	20	25	30	36	40	50	60	75	90	100	120	150	180	200
K7R□15N□-D K7G□B(C)	1200	0.34 3.4	0.41 4.1	0.57 5.7	0.68 6.8	0.85 8.5	1.02 10.2	1.13 11.3	1.42 14.2	1.70 17.0	2.04 20.4	2.25 22.5	3.06 30.6	3.67 36.7	4.08 40.8	4.59 45.9	5	5	5	5	5	5	5	5	5
	90	0.12 1.2	0.15 1.5	0.20 2.0	0.24 2.4	0.30 3.0	0.36 3.6	0.41 4.1	0.51 5.1	0.61 6.1	0.73 7.3	0.73 7.3	0.91 9.1	1.09 10.9	1.31 13.1	1.46 14.6	1.64 16.4	1.97 19.7	2.46 24.6	2.95 29.5	3.28 32.8	3.94 39.4	4.92 49.2	5	5

● Single-phase 200V/240V

unit = above : N · m / below : kgfcm

Model	Ratio	Speed (rpm)																								
		3	3.6	5	6	7.5	9	10	12.5	15	18	20	25	30	36	40	50	60	75	90	100	120	150	180	200	
K7R□15N□-D K7G□B(C)	1200	200V/220V/230V/ 240V/50Hz	0.33 3.3	0.39 3.9	0.55 5.5	0.66 6.6	0.82 8.2	0.98 9.8	1.09 10.9	1.37 13.7	1.64 16.4	1.97 19.7	2.46 24.6	2.95 29.5	3.54 35.4	3.94 39.4	4.43 44.3	5	5	5	5	5	5	5	5	5
		200V/220V/ 230V/60Hz	0.28 2.8	0.34 3.4	0.47 4.7	0.56 5.6	0.70 7.0	0.84 8.4	0.93 9.3	1.16 11.6	1.40 14.0	1.68 16.8	1.68 16.8	2.10 21.0	2.52 25.2	3.02 30.2	3.35 33.5	3.77 37.7	4.53 45.3	5	5	5	5	5	5	5
	90	200V/230V/ 50Hz/60Hz	0.13 1.3	0.16 1.6	0.22 2.2	0.27 2.7	0.33 3.3	0.40 4.0	0.45 4.5	0.56 5.6	0.67 6.7	0.80 8.0	0.80 8.0	1.00 10.0	1.20 12.0	1.44 14.4	1.60 16.0	1.80 18.0	2.17 21.7	2.71 27.1	3.25 32.5	3.61 36.1	4.33 43.3	5	5	5
		220V/50Hz/60Hz/ 240V/50Hz	0.12 1.2	0.15 1.5	0.20 2.0	0.24 2.4	0.30 3.0	0.36 3.6	0.41 4.1	0.51 5.1	0.61 6.1	0.73 7.3	0.73 7.3	0.91 9.1	1.09 10.9	1.31 13.1	1.46 14.6	1.64 16.4	1.97 19.7	2.46 24.6	2.95 29.5	3.28 32.8	3.94 39.4	4.92 49.2	5	5

- * Gearhead and decimal gearhead are sold separately.
- * The code in □ of gearhead model is for gear ratio.
- * ■ color indicates that the output shaft of the geared motor rotates in the same direction as the output shaft of the motor. Others indicate rotation in the opposite direction.
- * If you are to have less ratio than the ratio in the table, you can install the decimal gearhead, which has one tenth of the ratio, between the gearhead and the motor. In this case, the permissible torque is 5N · m/50kgfcm.
- * RPM is based on motor's synchronous rpm (50HZ:1500rpm, 60HZ:1800rpm) and calculated by dividing gear ratio. Actual rpm is 2~20% less than indicating rpm according to load size.

GEARHEADS

CONNECTION DIAGRAMS

Connect Cr circuit for absorbing surge voltage as connection diagram to protect contact point.
 $R_o = 5 - 200\Omega$
 $C_o = 0.1 \sim 0.2\mu F$ 200WV(400WV)

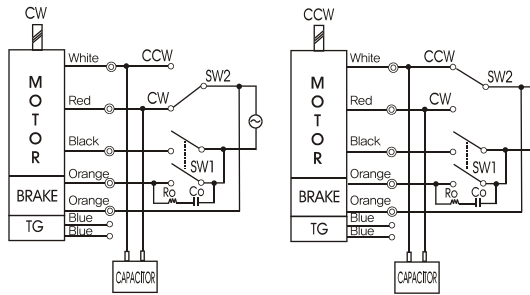

※The direction of motor rotation is as viewed from the front shaft end of the motor

DIMENSIONS

K7G□B(C)



K7RG15N□-D + K7G□B(C)



DECIMAL GEARHEAD

K7G10BX

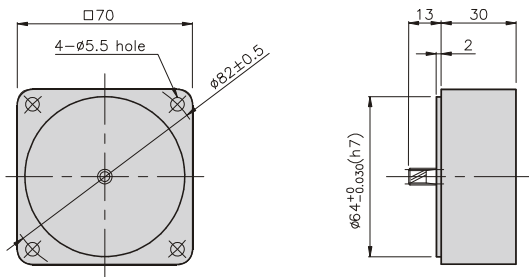

GEARHEAD

K7G□B(C)

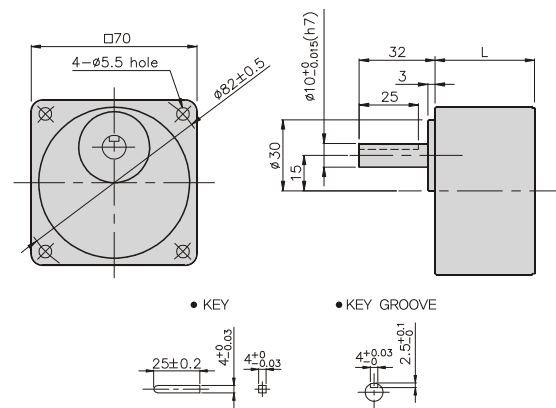

DIMENSION TABLE

PART No.	L	Application Model	Mounting BOLT
01	32	K7G3~18B(C)	M5 P0.8 X 50
02	42	K7G20~200B(C)	M5 P0.8 X 65
03	30	K7G10BX	M5 P0.8 X 90

WEIGHT

PART	WEIGHT(kg)	
MOTOR	1.42	
DECIMAL GEAR HEAD	0.32	
GEAR HEAD	K7G3~18B(C)	0.38
	K7G20~40B(C)	0.46
	K7G50~200B(C)	0.51

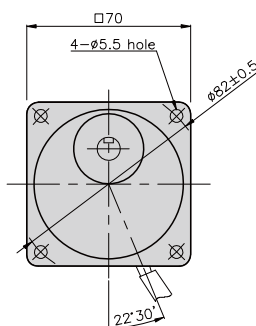

K7RG15N□-D + K7G□B(C)

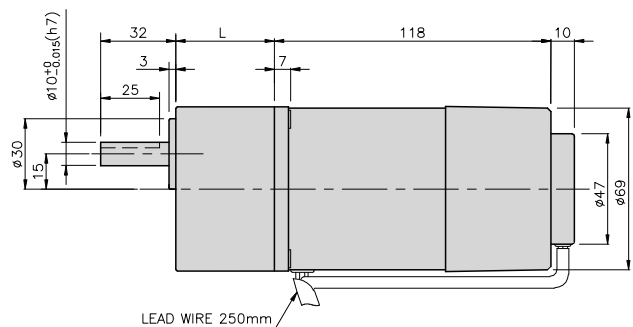

SPEED CONTROL & BRAKE MOTOR

25W

□80mm

K8RS25N□-D

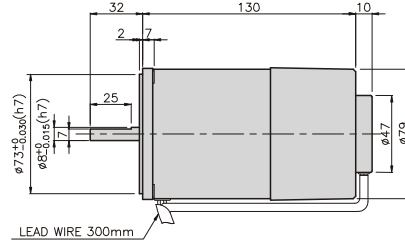
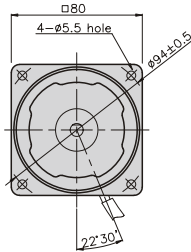

SPECIFICATIONS

25W 30 minutes rating, four poles

Model	Voltage (V)	Frequency (Hz)	Speed Range (rpm)	Permissible Torque		Start T. (N*m/ Kgf*cm)	Current (A)	Condenser (μF)	Friction T. (N*m/ Kgf*cm)
				1200rpm (N*m/ Kgf*cm)	90rpm (N*m/ Kgf*cm)				
K8R□25NJ-D	100	50	90 ~ 1400	0,22/2,2	0,06/0,6	0,105/1,05	0,85	10	0,4/4
		60	90 ~ 1700						
K8R□25NU-D	110	60	90 ~ 1700	0,22/2,2	0,06/0,6	0,1/1	0,7	6	0,4/4
	115						0,75		
K8R□25NL-D	200	50	90 ~ 1400	0,21/2,1	0,055/0,55	0,11/1,1	0,4	2,5	0,4/4
		60	90 ~ 1700	0,16/1,6	0,048/0,48		0,43		
K8R□25NC-D	220	50	90 ~ 1400	0,21/2,1	0,055/0,55	0,09/0,9	0,4	2	0,4/4
		60	90 ~ 1700	0,16/1,6	0,048/0,48				
	230	50	90 ~ 1400	0,21/2,1	0,055/0,55	0,1/1			
		60	90 ~ 1700	0,16/1,6	0,048/0,48				
K8R□25ND-D	240	50	90 ~ 1400	0,21/2,1	0,05/0,55	0,09/0,9	0,43	1,5	0,4/4

* □ : SHAFT SHAPE (S : STRAIGHT, G : PINION)

RATED TORQUE OF GEARHEAD

● Single-phase 100V/115V

unit = above : N · m / below : kgfcm

Model	Ratio	Speed(rpm)																								
		3	3,6	5	6	7,5	9	10	12,5	15	18	20	25	30	36	40	50	60	75	90	100	120	150	180	200	250
K8R□25N□-D K8G□B(C)	1200	0,53 5,3	0,64 6,4	0,89 8,9	1,07 10,7	1,34 13,4	1,60 16,0	1,78 17,8	2,23 22,3	2,67 26,7	3,21 32,1	3,21 32,1	4,01 40,1	4,81 48,1	5,77 57,7	6,42 64,2	7,22 72,2	8 80	8 80	8 80	8 80	8 80	8 80	8 80	8 80	8 80
	90	0,15 1,5	0,17 1,7	0,24 2,4	0,29 2,9	0,36 3,6	0,44 4,4	0,49 4,9	0,61 6,1	0,73 7,3	0,87 8,7	0,87 8,7	1,09 10,9	1,31 13,1	1,57 15,7	1,75 17,5	1,97 19,7	2,36 23,6	2,95 29,5	3,54 35,4	3,94 39,4	4,72 47,2	5,90 59,0	7,09 70,9	8 80	8 80

● Single-phase 200V/240V

unit = above : N · m / below : kgfcm

Model	Ratio	Speed(rpm)																								
		3	3,6	5	6	7,5	9	10	12,5	15	18	20	25	30	36	40	50	60	75	90	100	120	150	180	200	250
K8R□25N□-D K8G□B(C)	1200	200V/220V/230V/240V/50Hz	0,51 5,1	0,61 6,1	0,85 8,5	1,02 10,2	1,28 12,8	1,53 15,3	1,70 17,0	2,13 21,3	2,55 25,5	3,06 30,6	3,06 30,6	3,83 38,3	4,59 45,9	5,51 55,1	6,12 61,2	6,89 68,9	8 80	8 80	8 80	8 80	8 80	8 80	8 80	8 80
		200V/220V/230V/60Hz	0,39 3,9	0,47 4,7	0,65 6,5	0,78 7,8	0,97 9,7	1,17 11,7	1,30 13,0	1,62 16,2	1,94 19,4	2,33 23,3	2,33 23,3	2,92 29,2	3,50 35,0	4,20 42,0	4,67 46,7	5,25 52,5	6,30 63,0	7,87 78,7	8 80	8 80	8 80	8 80	8 80	8 80
	90	200V/220V/230V/240V/50Hz	0,13 1,3	0,16 1,6	0,22 2,2	0,27 2,7	0,33 3,3	0,40 4,0	0,45 4,5	0,56 5,6	0,67 6,7	0,80 8,0	0,80 8,0	1,00 10,0	1,20 12,0	1,44 14,4	1,60 16,0	1,80 18,0	2,17 21,7	2,71 27,1	3,25 32,5	3,61 36,1	4,43 44,3	5,41 54,1	6,50 65,0	7,22 72,2
		200V/220V/230V/60Hz	0,12 1,2	0,14 1,4	0,19 1,9	0,23 2,3	0,29 2,9	0,35 3,5	0,39 3,9	0,49 4,9	0,58 5,8	0,70 7,0	0,70 7,0	0,87 8,7	1,05 10,5	1,26 12,6	1,40 14,0	1,57 15,7	1,89 18,9	2,36 23,6	2,83 28,3	3,15 31,5	3,78 37,8	4,72 47,2	5,67 56,7	6,30 63,0

* Gearhead and decimal gearhead are sold separately.

* The code in □ of gearhead model is for gear ratio.

* ■ color indicates that the output shaft of the geared motor rotates in the same direction as the output shaft of the motor, Others indicate rotation in the opposite direction.

* If you are to have less ratio than the ratio in the table, you can install the decimal gearhead, which has one tenth of the ratio, between the gearhead and the motor. In this case, the permissible torque is 8N · m/80kgfcm. But, if you install 1/25~1/40 gearhead, the permissible torque is 6N · m/60kgfcm.

* RPM is based on motor's synchronous rpm (50HZ:1500rpm, 60HZ:1800rpm) and calculated by dividing gear ratio. Actual rpm is 2~20% less than indicating rpm according to load size.

GEARHEADS

CONNECTION DIAGRAMS

Connect Cr circuit for absorbing surge voltage as connection diagram to protect contact point.
 $R_o = 5 - 200\Omega$
 $C_o = 0.1 \sim 0.2\mu F$ 200WV(400WV)

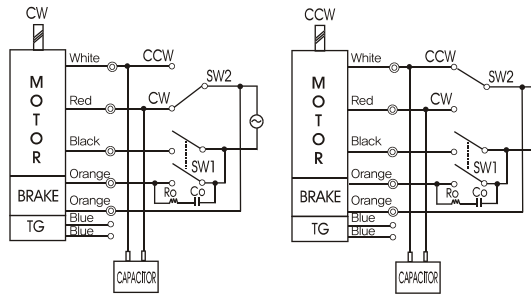

※The direction of motor rotation is as viewed from the front shaft end of the motor

DIMENSIONS

K8G□B(C)



K8RG25N□-D + K8G□B(C)



DECIMAL GEARHEAD

K8G10BX

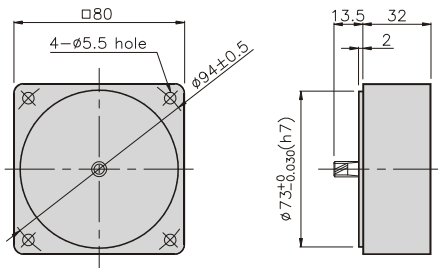

GEARHEAD

K8G□B(C)

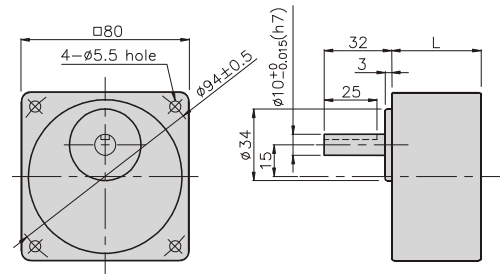

• KEY

• KEY GROOVE

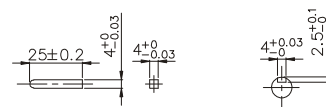

DIMENSION TABLE

PART No.	L	Application Model	Mounting BOLT
01	32	K8G3~18B(C)	M5 P0.8 X 50
02	42.5	K8G20~250B(C)	M5 P0.8 X 65
03	32	K8G10BX	M5 P0.8 X 95

WEIGHT

PART	WEIGHT(kg)	
MOTOR	1.94	
DECIMAL GEAR HEAD	0.46	
GEAR HEAD	K8G3~18B(C)	0.51
	K8G20~40B(C)	0.64
	K8G50~250B(C)	0.70

K8RG25N□-D + K8G□B(C)

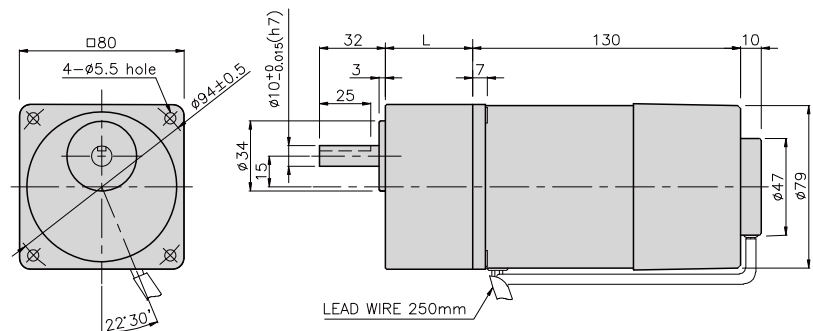

LEAD WIRE 250mm

SPEED CONTROL & BRAKE MOTOR

40W

□90mm

K9RS40N□-D

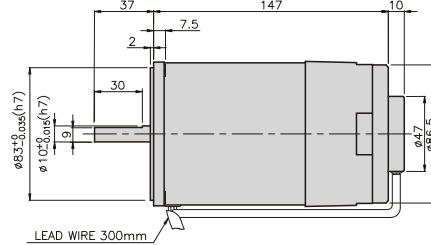
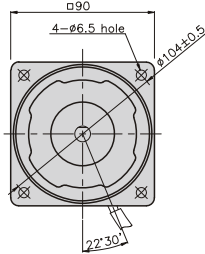

SPECIFICATIONS

40W 30 minutes rating, four poles

Model	Voltage (V)	Frequency (Hz)	Speed Range (rpm)	Permissible Torque		Start T. (N*m/ Kgf*cm)	Current (A)	Condenser (μF)	Friction T. (N*m/ Kgf*cm)
				1200rpm (N*m/ Kgf*cm)	90rpm (N*m/ Kgf*cm)				
K9R□40NJ-D	100	50	90 ~ 1400	0.3/3	0.075/0.75	0.17/1.7	1.5	16	1/10
		60	90 ~ 1700						
K9R□40NU-D	110	60	90 ~ 1700	0.3/3	0.075/0.75	0.14/1.4	1.5	10	1/10
	115						1.3		
K9R□40NL-D	200	50	90 ~ 1400	0.33/3.3	0.07/0.7	0.17/1.7	0.65	4	1/10
		60	90 ~ 1700	0.26/2.6			0.72		
K9R□40NC-D	220	50	90 ~ 1400	0.33/3.3	0.07/0.7	0.17/1.7	0.6	3.5	1/10
		60	90 ~ 1700	0.26/2.6			0.64		
	230	50	90 ~ 1400	0.33/3.3		0.17/1.7	0.6		
		60	90 ~ 1700	0.26/2.6		0.16/1.6	0.64		
K9R□40ND-D	240	50	90 ~ 1400	0.33/3.3	0.07/0.7	0.16/1.6	0.63	3	1/10

* □ : SHAFT SHAPE (S : STRAIGHT, G : PINION)

RATED TORQUE OF GEARHEAD

● Single-phase 100V/115V

unit = above : N · m / below : kgfcm

Model	Ratio	Speed (rpm)																							
		3	3.6	5	6	7.5	9	10	12.5	15	18	20	25	30	36	40	50	60	75	90	100	120	150	180	200
K9R□40N□-D K9G□B(C)	1200	0.73 7.3	0.87 8.7	1.22 12.2	1.46 14.6	1.82 18.2	2.19 21.9	2.43 24.3	3.04 30.4	3.65 36.5	4.37 43.7	5.47 54.7	6.56 65.6	7.87 78.7	8.75 87.5	9.84 98.4	10 100	10 100	10 100	10 100	10 100	10 100	10 100	10 100	10 100
	90	0.18 1.8	0.22 2.2	0.30 3.0	0.36 3.6	0.46 4.6	0.55 5.5	0.61 6.1	0.76 7.6	0.91 9.1	1.09 10.9	1.37 13.7	1.64 16.4	1.97 19.7	2.19 21.9	2.46 24.6	2.95 29.5	3.69 36.9	4.43 44.3	4.92 49.2	5.90 59.0	7.38 73.8	8.86 88.6	10 100	

● Single-phase 200V/240V

unit = above : N · m / below : kgfcm

Model	Ratio	Speed (rpm)																							
		3	3.6	5	6	7.5	9	10	12.5	15	18	20	25	30	36	40	50	60	75	90	100	120	150	180	200
K9R□40N□-D K9G□B(C)	1200	200V/220V/230V 240V/50Hz	0.80 8.0	0.96 9.6	1.34 13.4	1.60 16.0	2.00 20.0	2.41 24.1	2.67 26.7	3.34 33.4	4.01 40.1	4.81 48.1	4.81 48.1	6.01 60.1	7.22 72.2	8.66 86.6	9.62 96.2	10 100	10 100	10 100	10 100	10 100	10 100	10 100	10 100
		200V/220V 230V/60Hz	0.63 6.3	0.76 7.6	1.05 10.5	1.26 12.6	1.58 15.8	1.90 19.0	2.11 21.1	2.63 26.3	3.16 31.6	3.79 37.9	3.79 37.9	4.74 47.4	5.69 56.9	6.82 68.2	7.58 75.8	8.53 85.3	10 100	10 100	10 100	10 100	10 100	10 100	10 100
	90	0.17 1.7	0.20 2.0	0.28 2.8	0.34 3.4	0.43 4.3	0.51 5.1	0.57 5.7	0.71 7.1	0.85 8.5	1.02 10.2	1.28 12.8	1.53 15.3	1.84 18.4	2.04 20.4	2.30 23.0	2.76 27.6	3.44 34.4	4.13 41.3	4.59 45.9	5.51 55.1	6.89 68.9	8.27 82.7	9.19 91.9	

* Gearhead and decimal gearhead are sold separately.

* The code in □ of gearhead model is for gear ratio.

* ■ color indicates that the output shaft of the geared motor rotates in the same direction as the output shaft of the motor. Others indicate rotation in the opposite direction.

* If you are to have less ratio than the ratio in the table, you can install the decimal gearhead, which has one tenth of the ratio, between the gearhead and the motor. In this case, the permissible torque is 10N · m/100kgfcm.

* RPM is based on motor's synchronous rpm (50HZ:1500rpm, 60HZ:1800rpm) and calculated by dividing gear ratio. Actual rpm is 2~20% less than indicating rpm according to load size.

GEARHEADS

CONNECTION DIAGRAMS

Connect Cr circuit for absorbing surge voltage as connection diagram to protect contact point.
 $R_o = 5 - 200\Omega$
 $C_o = 0.1 \sim 0.2\mu F$ 200WV(400WV)

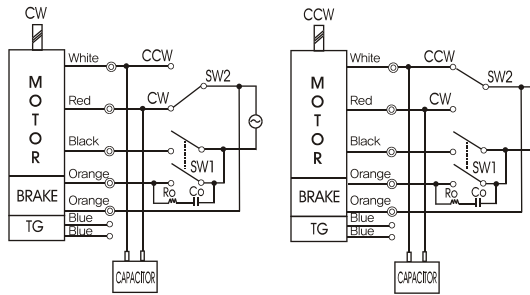

※The direction of motor rotation is as viewed from the front shaft end of the motor

DIMENSIONS

K9G□B(C)



K9RG40N□-D + K9G□B(C)



DECIMAL GEARHEAD

K9G10BX

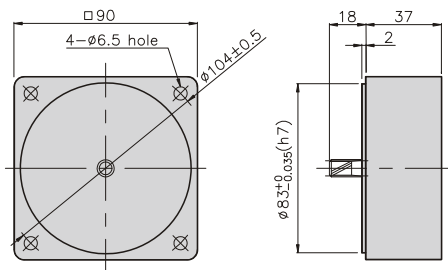

GEARHEAD

K9G□B(C)

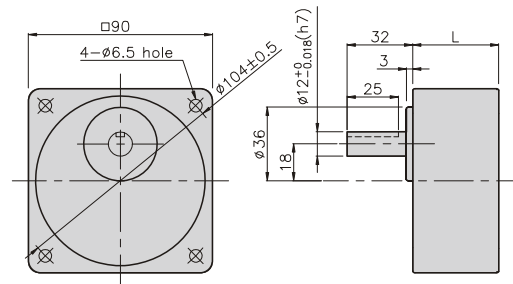

• KEY

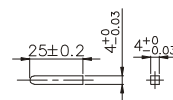

• KEY GROOVE

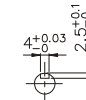

DIMENSION TABLE

PART No.	L	Application Model	Mounting BOLT
01	42	K9G3~18B(C)	M6 P1.0 X 65
02	60	K9G20~200B(C)	M6 P1.0 X 80
03	37	K9G10BX	M6 P1.0 X 120

WEIGHT

PART	WEIGHT(kg)	
MOTOR	2.98	
DECIMAL GEAR HEAD	0.60	
GEAR HEAD	K9G3~18B(C)	0.78
	K9G20~40B(C)	1.04
	K9G50~200B(C)	1.14

K9RG40N□-D + K9G□B(C)

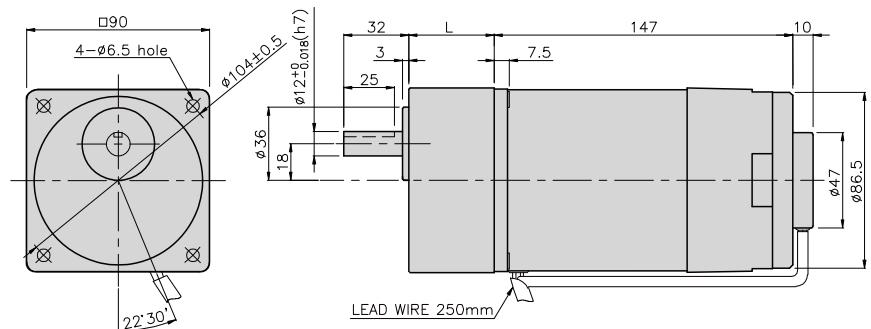

SPEED CONTROL & BRAKE MOTOR

60W

□90mm

K9RS60F□-D

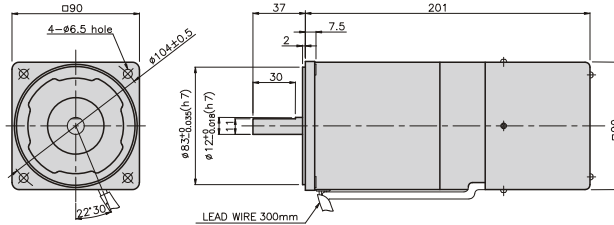

SPECIFICATIONS

60W 30 minutes rating, four poles

Model	Voltage (V)	Frequency (Hz)	Speed Range (rpm)	Permissible Torque		Start T. (N*m/Kgf*cm)	Current (A)	Condenser (μF)	Friction T. (N*m/Kgf*cm)
				1200rpm (N*m/Kgf*cm)	90rpm (N*m/Kgf*cm)				
K9R□60FJ-D	100	50	90 ~ 1400	0.5/5	0.17/1.7	0.3/3	2.5	25	1/10
		60	90 ~ 1700						
K9R□60FU-D	110	60	90 ~ 1700	0.5/5	0.17/1.7	0.295/2.95	2.1	17	1/10
	115						2.2		
K9R□60FL-D	200	50	90 ~ 1400	0.5/5	0.15/1.5	0.26/2.6	0.72	6	1/10
		60	90 ~ 1700	0.48/4.8	0.17/1.7	0.23/2.3	0.76		
K9R□60FC-D	220	50	90 ~ 1400	0.5/5	0.15/1.5	0.3/3	0.95	5	1/10
		60	90 ~ 1700	0.48/4.8	0.17/1.7	0.26/2.6	0.94		
	230	50	90 ~ 1400	0.5/5	0.15/1.5	0.3/3	1		
		60	90 ~ 1700	0.48/4.8	0.17/1.7	0.26/2.6	1.2		
K9R□60FD-D	240	50	90 ~ 1400	0.5/5	0.15/1.5	0.32/3.2	1.2	5	1/10

* □ : SHAFT SHAPE (S : STRAIGHT, G : PINION)

RATED TORQUE OF GEARHEAD

● Single-phase 100V/115V

unit = above : N · m / below : kgfcm

Model	Ratio	Speed(rpm)																								
		3	3.6	5	6	7.5	9	10	12.5	15	18	20	25	30	36	40	50	60	75	90	100	120	150	180	200	
K9R□60F□-D K9P□B, BF	1200	1.22 12.2	1.46 14.6	2.03 20.3	2.43 24.3	3.04 30.4	3.65 36.5	4.05 40.5	4.56 45.6	5.47 54.7	6.56 65.6	7.29 72.9	8.20 82.0	9.84 98.4	11.81 118.1	13.12 131.2	16.40 164.0	19.68 196.8	20 200	20 200	20 200	20 200	20 200	20 200	20 200	20 200
	90	0.41 4.1	0.50 5.0	0.69 6.9	0.83 8.3	1.03 10.3	1.24 12.4	1.38 13.8	1.55 15.5	1.86 18.6	2.23 22.3	2.48 24.8	2.79 27.9	3.35 33.5	4.02 40.2	4.46 44.6	5.58 55.8	6.69 66.9	7.53 75.3	9.03 90.3	10.04 100.4	12.05 120.5	15.06 150.6	18.07 180.7	20 200	

● Single-phase 200V/240V

unit = above : N · m / below : kgfcm

Model	Ratio	Speed(rpm)																								
		3	3.6	5	6	7.5	9	10	12.5	15	18	20	25	30	36	40	50	60	75	90	100	120	150	180	200	
K9R□60F□-D K9P□B, BF	1200	200V/220V/230V/240V/50Hz	1.22 12.2	1.46 14.6	2.03 20.3	2.43 24.3	3.04 30.4	3.65 36.5	4.05 40.5	4.56 45.6	5.47 54.7	6.56 65.6	7.29 72.9	8.20 82.0	9.84 98.4	11.81 118.1	13.12 131.2	16.40 164.0	19.68 196.8	20 200	20 200	20 200	20 200	20 200	20 200	20 200
		200V/220V/230V/60Hz	1.17 11.7	1.40 14.0	1.94 19.4	2.33 23.3	2.92 29.2	3.50 35.0	3.89 38.9	4.37 43.7	5.25 52.5	6.30 63.0	7.00 70.0	7.87 78.7	9.45 94.5	11.34 113.4	12.60 126.0	15.75 157.5	18.90 189.0	20 200	20 200	20 200	20 200	20 200	20 200	20 200
	90	200V/220V/230V/240V/50Hz	0.36 3.6	0.44 4.4	0.61 6.1	0.73 7.3	0.91 9.1	1.09 10.9	1.22 12.2	1.37 13.7	1.64 16.4	1.97 19.7	2.19 21.9	2.46 24.6	2.95 29.5	3.54 35.4	3.94 39.4	4.92 49.2	5.90 59.0	6.64 66.4	7.97 79.7	8.86 88.6	10.63 106.3	13.29 132.9	15.94 159.4	17.71 177.1
		200V/220V/230V/60Hz	0.41 4.1	0.50 5.0	0.69 6.9	0.83 8.3	1.03 10.3	1.24 12.4	1.38 13.8	1.55 15.5	1.86 18.6	2.23 22.3	2.48 24.8	2.79 27.9	3.35 33.5	4.02 40.2	4.46 44.6	5.58 55.8	6.69 66.9	7.53 75.3	9.03 90.3	10.04 100.4	12.05 120.5	15.06 150.6	18.07 180.7	20 200

- * Gearhead and decimal gearhead are sold separately.
- * The code in □ of gearhead model is for gear ratio.
- * color indicates that the output shaft of the geared motor rotates in the same direction as the output shaft of the motor. Others indicate rotation in the opposite direction.
- * If you are to have less ratio than the ratio in the table, you can install the decimal gearhead, which has one tenth of the ratio, between the gearhead and the motor. In this case, the permissible torque is 20N · m/200kgfcm.
- * RPM is based on motor's synchronous rpm (50HZ:1500rpm, 60HZ:1800rpm) and calculated by dividing gear ratio. Actual rpm is 2~20% less than indicating rpm according to load size.

GEARHEADS

CONNECTION DIAGRAMS

Connect Cr circuit for absorbing surge voltage as connection diagram to protect contact point.
 $R_o = 5 - 200\Omega$
 $C_o = 0.1 \sim 0.2\mu F$ 200WV(400WV)

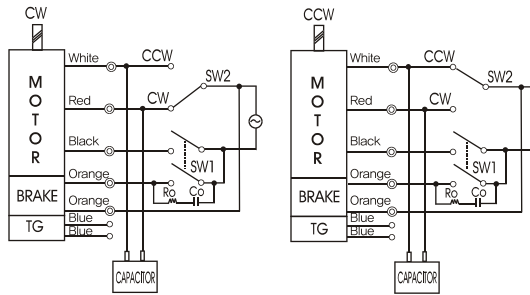

※The direction of motor rotation is as viewed from the front shaft end of the motor

DIMENSIONS

K9P□B



K9P□BF



DECIMAL GEARHEAD

K9P10BX

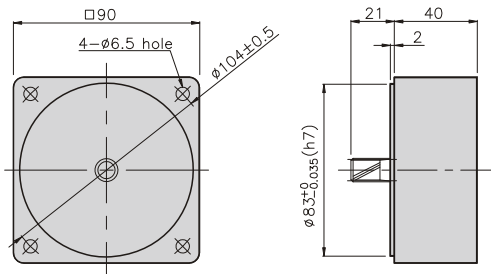

GEARHEAD

K9P□B

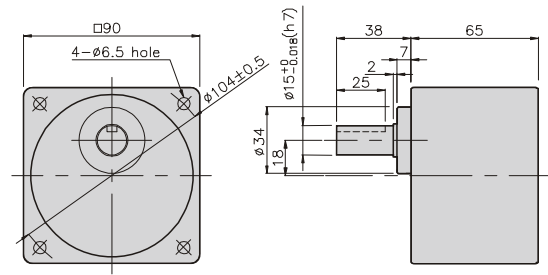

GEARHEAD

K9P□BF

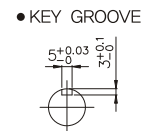
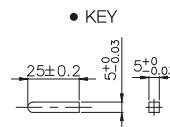
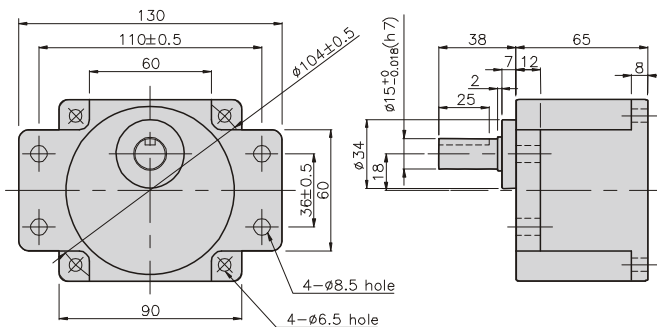

GEARHEADS

DIMENSIONS

K9RP60F□-D + K9P□B



K9RP60F□-D + K9P□BF



K9RP60F□-D + K9P□B

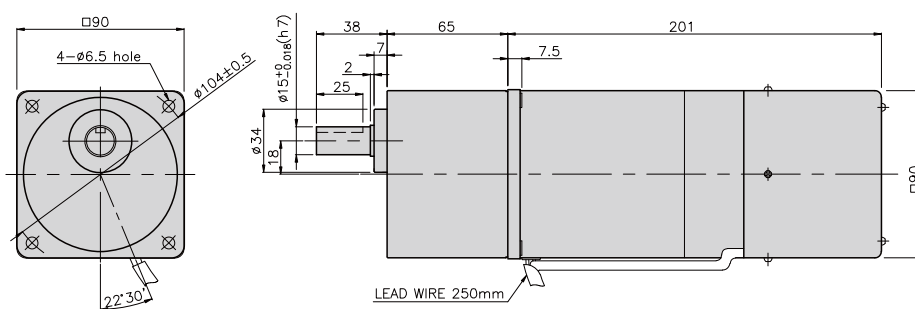

DIMENSION TABLE

PART No.	L	Application Model	Mounting BOLT
01	65	K9P3~200B	M6 P1,0 X 95
02	40	K9P10BX	M6 P1,0 X 140

WEIGHT

PART	WEIGHT(kg)	
MOTOR	3,58	
DECIMAL GEAR HEAD	0,62	
GEAR HEAD	K9P3~10B	1,22
	K9P12,5~20B	1,32
	K9P25~60B	1,42
	K9P75~200B	1,45

K9RP60F□-D + K9P□BF

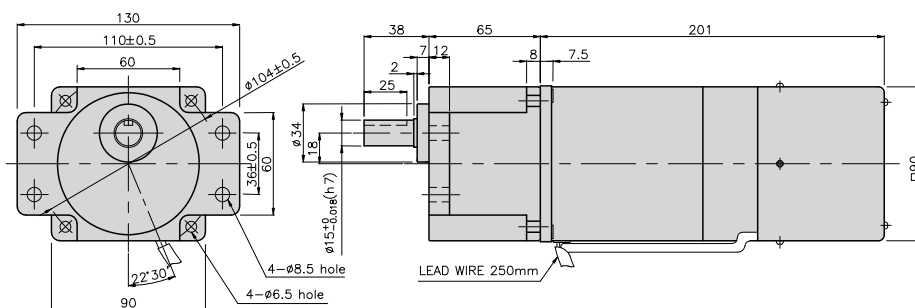

DIMENSION TABLE

PART No.	L	Application Model	Mounting BOLT
01	65	K9P3~200BF	M6 P1,0 X 25
02	40	K9P10BX	M6 P1,0 X 65

WEIGHT

PART	WEIGHT(kg)	
MOTOR	3,58	
DECIMAL GEAR HEAD	0,62	
GEAR HEAD	K9P3~10BF	1,22
	K9P12,5~18BF	1,30
	K9P20~60BF	1,42
	K9P75~200BF	1,44

SPEED CONTROL & BRAKE MOTOR

90W

□90mm

K9RS90F□-D

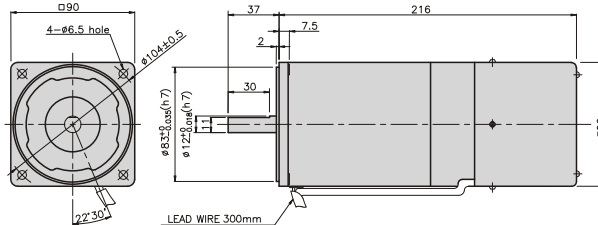

SPECIFICATIONS

90W 30 minutes rating, four poles

Model	Voltage (V)	Frequency (Hz)	Speed Range (rpm)	Permissible Torque		Start T. (N*m/ Kgf*cm)	Current (A)	Condenser (μF)	Friction T. (N*m/ Kgf*cm)
				1200rpm (N*m/ Kgf*cm)	90rpm (N*m/ Kgf*cm)				
K9R□90FJ-D	100	50	90 ~ 1400	0.75/7.5	0.25/2.5	0.4/4	3.6	35	1/10
			90 ~ 1700						
K9R□90FU-D	110	60	90 ~ 1700	0.75/7.5	0.25/2.5	0.38/3.8	3	25	1/10
	115						3.2		
K9R□90FL-D	200	50	90 ~ 1400	0.75/7.5	0.25/2.5	0.4/4	1.4	8	1/10
			90 ~ 1700		0.28/2.8		1.5		
K9R□90FC-D	220	50	90 ~ 1400	0.75/7.5	0.25/2.5	0.4/4	1.2	7	1/10
			90 ~ 1700		0.28/2.8		1.4		
	230	50	90 ~ 1400		0.25/2.5	0.43/4.3	1.2		
			90 ~ 1700		0.28/2.8		1.4		
K9R□90FD-D	240	50	90 ~ 1400	0.75/7.5	0.25/2.5	0.4/4	1.3	6	1/10

* □ : SHAFT SHAPE (S : STRAIGHT, G : PINION)

RATED TORQUE OF GEARHEAD

● Single-phase 100V/115V

unit = above : N · m / below : kgfcm

Model	Ratio	Speed (rpm)																							
		3	3.6	5	6	7.5	9	10	12.5	15	18	20	25	30	36	40	50	60	75	90	100	120	150	180	200
K9R□90F□-D K9P□B, BF	1200	1.82 18.2	2.19 21.9	3.04 30.4	3.65 36.5	4.56 45.6	5.47 54.7	6.08 60.8	6.83 68.3	8.20 82.0	9.84 98.4	10.94 109.4	12.30 123.0	14.76 147.6	17.71 177.1	19.68 196.8	20 200	20 200	20 200	20 200	20 200	20 200	20 200	20 200	20 200
	90	0.61 6.1	0.73 7.3	1.01 10.1	1.22 12.2	1.52 15.2	1.82 18.2	2.03 20.3	2.28 22.8	2.73 27.3	3.28 32.8	3.65 36.5	4.10 41.0	4.92 49.2	5.90 59.0	6.56 65.6	8.20 82.0	9.84 98.4	11.07 110.7	13.29 132.9	14.76 147.6	17.71 177.1	20 200	20 200	20 200

● Single-phase 200V/240V

unit = above : N · m / below : kgfcm

Model	Ratio	Speed (rpm)																								
		3	3.6	5	6	7.5	9	10	12.5	15	18	20	25	30	36	40	50	60	75	90	100	120	150	180	200	
K9R□90F□-D K9P□B, BF	1200	1.82 18.2	2.19 21.9	3.04 30.4	3.65 36.5	4.56 45.6	5.47 54.7	6.08 60.8	6.83 68.3	8.20 82.0	9.84 98.4	10.94 109.4	12.30 123.0	14.76 147.6	17.71 177.1	19.68 196.8	20 200	20 200	20 200	20 200	20 200	20 200	20 200	20 200	20 200	
	90	200V/220V/230V 240V/50Hz	0.61 6.1	0.73 7.3	1.01 10.1	1.22 12.2	1.52 15.2	1.82 18.2	2.03 20.3	2.28 22.8	2.73 27.3	3.28 32.8	3.65 36.5	4.10 41.0	4.92 49.2	5.90 59.0	6.56 65.6	8.20 82.0	9.84 98.4	11.07 110.7	13.29 132.9	14.76 147.6	17.71 177.1	20 200	20 200	20 200
		200V/220V 230V/50Hz	0.68 6.8	0.82 8.2	1.13 11.3	1.36 13.6	1.70 17.0	2.04 20.4	2.27 22.7	2.55 25.5	3.06 30.6	3.67 36.7	4.08 40.8	4.59 45.9	5.51 55.1	6.61 66.1	7.35 73.5	9.19 91.9	11.02 110.2	12.40 124.0	14.88 148.8	16.53 165.3	19.84 198.4	20 200	20 200	20 200

- * Gearhead and decimal gearhead are sold separately.
- * The code in □ of gearhead model is for gear ratio.
- * ■ color indicates that the output shaft of the geared motor rotates in the same direction as the output shaft of the motor, Others indicate rotation in the opposite direction.
- * If you are to have less ratio than the ratio in the table, you can install the decimal gearhead, which has one tenth of the ratio, between the gearhead and the motor. In this case, the permissible torque is 20N · m/200kgfcm.
- * RPM is based on motor's synchronous rpm (50HZ:1500rpm, 60HZ:1800rpm) and calculated by dividing gear ratio. Actual rpm is 2~20% less than indicating rpm according to load size.

GEARHEADS

RATED TORQUE OF GEARHEAD

● Single-phase 100V/115V

unit = above : N · m / below : kgfcm

Model Motor/ Gearhead	Ratio Speed(rpm)	3	3.6	5	6	7.5	9	10	12.5	15	18	20	25	30	36	40	50	60	75	90	100	120	150	180	200
		K9R□90F□-D K9P□BU, BUF	1200	1.82 18.2	2.19 21.9	3.04 30.4	3.65 36.5	4.56 45.6	5.47 54.7	6.08 60.8	6.83 68.3	8.20 82.0	9.84 98.4	10.94 109.4	12.30 123.0	14.76 147.6	17.71 177.1	19.68 196.8	24.60 246	29.52 295	30 300	30 300	30 300	30 300	30 300
90	0.61 6.1		0.73 7.3	1.01 10.1	1.22 12.2	1.52 15.2	1.82 18.2	2.03 20.3	2.28 22.8	2.73 27.3	3.28 32.8	3.65 36.5	4.10 41.0	4.92 49.2	5.90 59.0	6.56 65.6	8.20 82.0	9.84 98.4	11.07 110.7	13.29 132.9	14.76 147.6	17.71 177.1	22.14 221.4	26.57 265.7	29.52 295.2

● Single-phase 200V/240V

unit = above : N · m / below : kgfcm

Model Motor/ Gearhead	Ratio Speed(rpm)	3	3.6	5	6	7.5	9	10	12.5	15	18	20	25	30	36	40	50	60	75	90	100	120	150	180	200	
		K9R□60F□-D K9P□BU, BUF	1200	1.82 18.2	2.19 21.9	3.04 30.4	3.65 36.5	4.56 45.6	5.47 54.7	6.08 60.8	6.83 68.3	8.20 82.0	9.84 98.4	10.94 109.4	12.30 123.0	14.76 147.6	17.71 177.1	19.68 196.8	24.60 246	29.52 295	30 300	30 300	30 300	30 300	30 300	30 300
90	200V/220V/230V 240V/50Hz		0.61 6.1	0.73 7.3	1.01 10.1	1.22 12.2	1.52 15.2	1.82 18.2	2.03 20.3	2.28 22.8	2.73 27.3	3.28 32.8	3.65 36.5	4.10 41.0	4.92 49.2	5.90 59.0	6.56 65.6	8.20 82.0	9.84 98.4	11.07 110.7	13.29 132.9	14.76 147.6	17.71 177.1	22.14 221.4	26.57 265.7	29.52 295.2
	200V/220V 230V/60Hz		0.68 6.8	0.82 8.2	1.13 11.3	1.36 13.6	1.70 17.0	2.04 20.4	2.27 22.7	2.55 25.5	3.06 30.6	3.67 36.7	4.08 40.8	4.59 45.9	5.51 55.1	6.61 66.1	7.35 73.5	9.19 91.9	11.02 110.2	12.40 124.0	14.88 148.8	16.53 165.3	19.84 198.4	24.80 248.0	29.76 297.6	30 300

- * Gearhead and decimal gearhead are sold separately.
- * The code in □ of gearhead model is for gear ratio.
- * ■ color indicates that the output shaft of the geared motor rotates in the same direction as the output shaft of the motor. Others indicate rotation in the opposite direction.
- * If you are to have less ratio than the ratio in the table, you can install the decimal gearhead, which has one tenth of the ratio, between the gearhead and the motor. In this case, the permissible torque is $30N \cdot m/300kgfcm$.
- * RPM is based on motor's synchronous rpm (50HZ:1500rpm, 60HZ:1800rpm) and calculated by dividing gear ratio. Actual rpm is 2~20% less than indicating rpm according to load size.

CONNECTION DIAGRAMS

Connect Cr circuit for absorbing surge voltage as connection diagram to protect contact point.
 $R_o = 5 - 200\Omega$
 $C_o = 0.1 \sim 0.2\mu F$ 200WV(400WV)

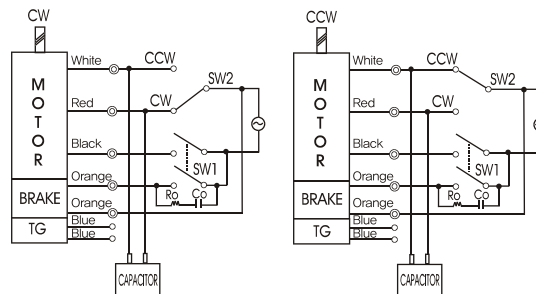

※The direction of motor rotation is as viewed from the front shaft end of the motor

GEARHEADS

DIMENSIONS

K9P□B



K9P□BF, BUF



K9P□BU



DECIMAL GEARHEAD

K9P10BX

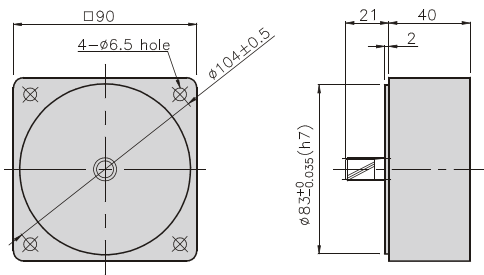

GEARHEAD

K9P□B

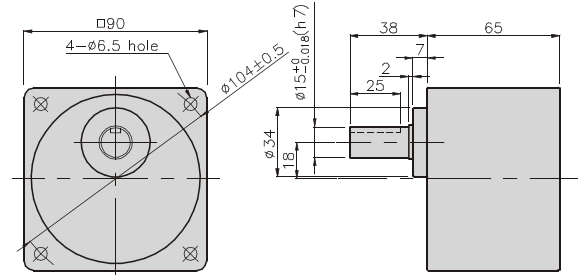

GEARHEAD

K9P□BF

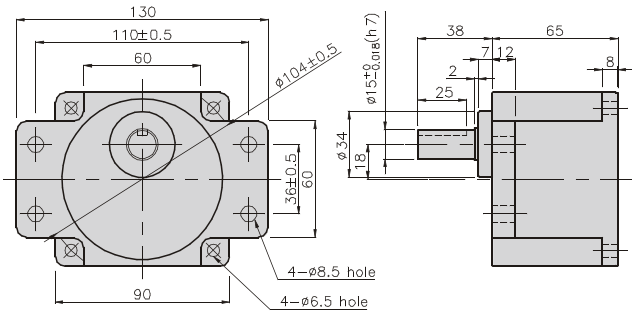

GEARHEAD

K9P□BU

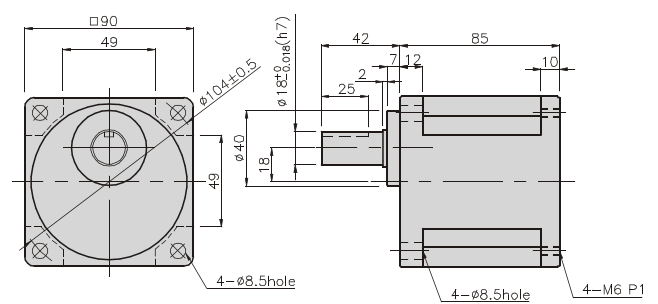

GEARHEAD

K9P□BUF

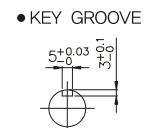
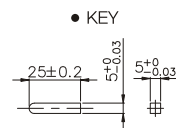
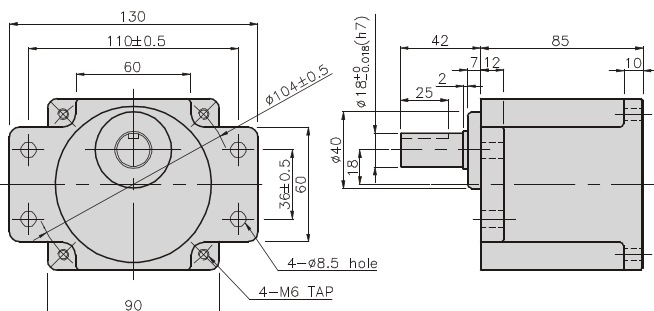

GEARHEADS

DIMENSIONS

K9RP90F□-D + K9P□B



K9RP90F□-D + K9P□BF, BUF



K9RP90F□-D + K9P□BU



K9RP90F□-D + K9P□B

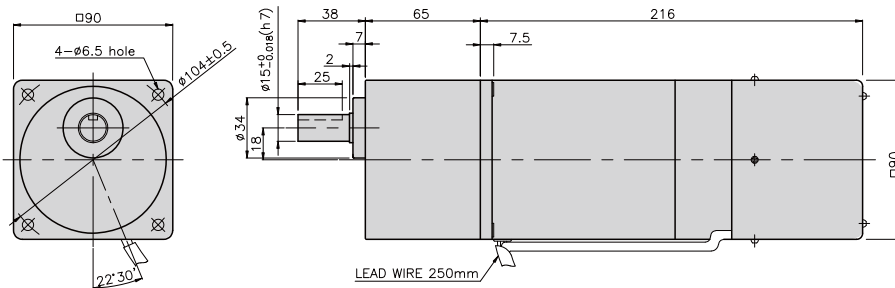

WEIGHT

PART	WEIGHT(kg)
MOTOR	4.06
DECIMAL GEAR HEAD	0.62

DIMENSION TABLE

PART No.	L	Application Model	Mounting BOLT
01	65	K9P3~200B	M6 P1.0 X 95
02	40	K9P10BX	M6 P1.0 X 140

WEIGHT

PART	WEIGHT(kg)
K9P3~10B	1.22
K9P12.5~20B	1.32
K9P25~60B	1.42
K9P75~200B	1.45

K9RP90F□-D + K9P□BF

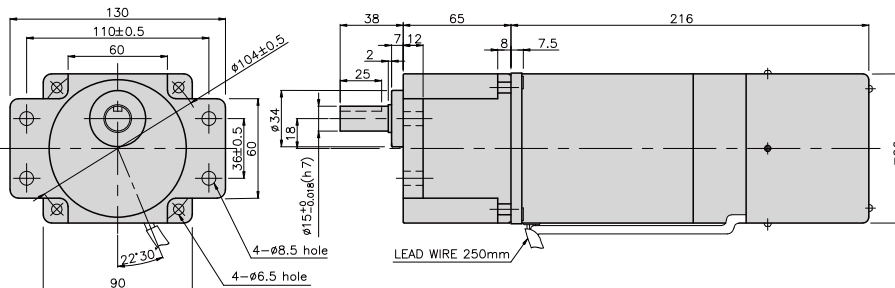

DIMENSION TABLE

PART No.	L	Application Model	Mounting BOLT
01	65	K9P3~200BF	M6 P1.0 X 25
02	40	K9P10BX	M6 P1.0 X 65

WEIGHT

PART	WEIGHT(kg)
K9P3~10BF	1.22
K9P12.5~20BF	1.30
K9P25~60BF	1.42
K9P75~200BF	1.44

K9RP90F□-D + K9P□BU

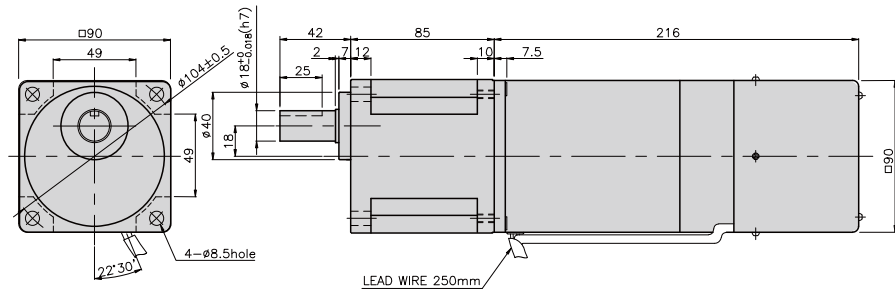

DIMENSION TABLE

PART No.	L	Application Model	Mounting BOLT
01	85	K9P3~200BU	M6 P1.0 X 20
02	40	K9P10BX	M6 P1.0 X 60

WEIGHT

PART	WEIGHT(kg)
K9P3~10BU	1.44
K9P12.5~20BU	1.55
K9P25~60BU	1.69
K9P75~200BU	1.74

K9RP90F□-D + K9P□BUF

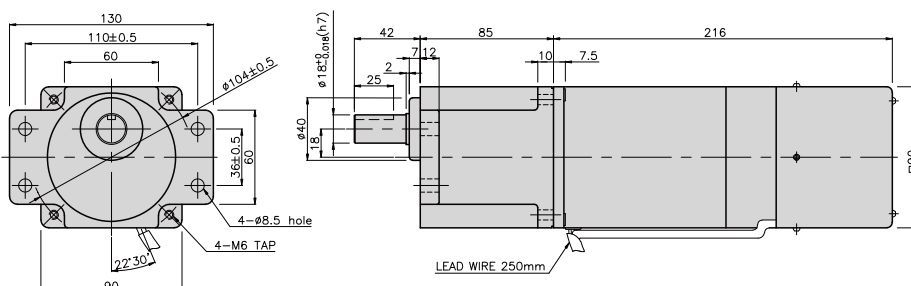

DIMENSION TABLE

PART No.	L	Application Model	Mounting BOLT
01	85	K9P3~200BUF	M6 P1.0 X 20
02	40	K9P10BX	M6 P1.0 X 65

WEIGHT

PART	WEIGHT(kg)
K9P3~10BUF	1.50
K9P12.5~20BUF	1.62
K9P25~60BUF	1.76
K9P75~200BUF	1.82

SPEED CONTROL & BRAKE MOTOR

120W

□90mm

K9RS120F□-D

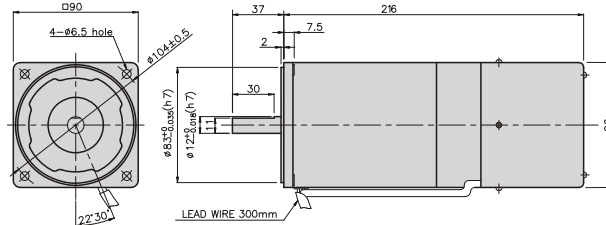

SPECIFICATIONS

120W 30 minutes rating, four poles

Model	Voltage (V)	Frequency (Hz)	Speed Range (rpm)	Permissible Torque		Start T. (N*m/Kgf*cm)	Current (A)	Condenser (μF)	Friction T. (N*m/Kgf*cm)
				1200rpm (N*m/Kgf*cm)	90rpm (N*m/Kgf*cm)				
K9R□120FJ-D	100	50	90 ~ 1400	0.85/8.5	0.31/3.1	0.45/4.5	3.6	40	1/10
			90 ~ 1700						
K9R□120FU-D	110	60	90 ~ 1700	0.8/8	0.28/2.8	0.4/4	3	25	1/10
			115						
K9R□120FL-D	200	50	90 ~ 1400	0.8/8	0.27/2.7	0.37/3.7	1.4	8.5	1/10
			90 ~ 1700						
K9R□120FC-D	220	50	90 ~ 1400	0.8/8	0.27/2.7	0.37/3.7	1.2	6	1/10
			90 ~ 1700						
		60	90 ~ 1400	0.78/7.8	0.29/2.9	0.42/4.2	1.4	7	
			90 ~ 1700						
K9R□120FD-D	240	50	90 ~ 1400	0.8/8	0.27/2.7	0.37/3.7	1.3	6	1/10

* □ : SHAFT SHAPE (S : STRAIGHT, G : PINION)

RATED TORQUE OF GEARHEAD

● Single-phase 100V/115V

unit = above : N · m / below : kgfcm

Model	Ratio	Speed(rpm)																								
		3	3.6	5	6	7.5	9	10	12.5	15	18	20	25	30	36	40	50	60	75	90	100	120	150	180	200	
K9R□120F□-D K9P□B, BF	1200	100V/50Hz	2.07	2.48	3.44	4.13	5.16	6.20	6.89	7.75	9.29	11.15	12.39	13.94	16.73	20	20	20	20	20	20	20	20	20	20	20
		110V/60Hz	1.94	2.33	3.24	3.89	4.86	5.83	6.48	7.29	8.75	10.50	11.66	13.12	15.75	18.90	20	20	20	20	20	20	20	20	20	20
	90	100V/50Hz	0.75	0.90	1.26	1.51	1.88	2.26	2.51	2.82	3.39	4.07	4.52	5.08	6.10	7.32	8.14	10.17	12.20	13.73	16.47	18.31	20	20	20	20
		110V/60Hz	0.68	0.82	1.13	1.36	1.70	2.04	2.27	2.55	3.06	3.67	4.08	4.59	5.51	6.61	7.35	9.19	11.02	12.40	14.88	16.53	19.84	20	20	20

● Single-phase 200V/240V

unit = above : N · m / below : kgfcm

Model	Ratio	Speed(rpm)																								
		3	3.6	5	6	7.5	9	10	12.5	15	18	20	25	30	36	40	50	60	75	90	100	120	150	180	200	
K9R□120F□-D K9P□B, BF	1200	200V/230V	1.94	2.33	3.24	3.89	4.86	5.83	6.48	7.29	8.75	10.50	11.66	13.12	15.75	18.90	20	20	20	20	20	20	20	20	20	20
		240V/50Hz	19.4	23.3	32.4	38.9	48.6	58.3	64.8	72.9	87.5	105.0	116.6	131.2	157.5	189.0	200	200	200	200	200	200	200	200	200	200
	90	200V/230V	1.90	2.27	3.16	3.79	4.74	5.69	6.32	7.11	8.53	10.24	11.37	12.79	15.35	18.42	20	20	20	20	20	20	20	20	20	20
		240V/60Hz	19.0	22.7	31.6	37.9	47.4	56.9	63.2	71.1	85.3	102.4	113.7	127.9	153.5	184.2	200	200	200	200	200	200	200	200	200	200

- * Gearhead and decimal gearhead are sold separately.
- * The code in □ of gearhead model is for gear ratio.
- * ■ color indicates that the output shaft of the geared motor rotates in the same direction as the output shaft of the motor. Others indicate rotation in the opposite direction.
- * If you are to have less ratio than the ratio in the table, you can install the decimal gearhead, which has one tenth of the ratio, between the gearhead and the motor. In this case, the permissible torque is 20N · m/200kgfcm.
- * RPM is based on motor's synchronous rpm (50HZ:1500rpm, 60HZ:1800rpm) and calculated by dividing gear ratio. Actual rpm is 2~20% less than indicating rpm according to load size.

GEARHEADS

RATED TORQUE OF GEARHEAD

● Single-phase 100V/115V

unit = above : N · m / below : kgfcm

Model Motor/ Gearhead	Ratio Speed(rpm)	3	3,6	5	6	7,5	9	10	12,5	15	18	20	25	30	36	40	50	60	75	90	100	120	150	180	200	
		K9R□120F□-D K9P□BU, BUF	1200	100V 50/60Hz	2,07 20,7	2,48 24,8	3,44 34,4	4,13 41,3	5,16 51,6	6,20 62,0	6,89 68,9	7,75 77,5	9,29 92,9	11,15 111,5	12,39 123,9	13,94 139,4	16,73 167,3	20,08 201	22,31 223	27,88 279	30 300	30 300	30 300	30 300	30 300	30 300
100V/115V 60Hz	1,94 19,4			2,33 23,3	3,24 32,4	3,89 38,9	4,86 48,6	5,83 58,3	6,48 64,8	7,29 72,9	8,75 87,5	10,50 105,0	11,66 116,6	13,12 131,2	15,75 157,5	18,90 189,0	21,00 210	26,24 262	30 300	30 300	30 300	30 300	30 300	30 300	30 300	30 300
90	100V 50/60Hz		0,75 7,5	0,90 9,0	1,26 12,6	1,51 15,1	1,88 18,8	2,26 22,6	2,51 25,1	2,82 28,2	3,39 33,9	4,07 40,7	4,52 45,2	5,08 50,8	6,10 61,0	7,32 73,2	8,14 81,4	10,17 101,7	12,20 122,0	13,73 137,3	16,47 164,7	18,31 183,1	21,97 219,7	27,46 274,6	30 300	30 300
	110V/115V 60Hz		0,68 6,8	0,82 8,2	1,13 11,3	1,36 13,6	1,70 17,0	2,04 20,4	2,27 22,7	2,55 25,5	3,06 30,6	3,67 36,7	4,08 40,8	4,59 45,9	5,51 55,1	6,61 66,1	7,35 73,5	9,19 91,9	11,02 110,2	12,40 124,0	14,88 148,8	16,53 165,3	19,84 198,4	24,80 248,0	29,76 297,6	30 300

● Single-phase 200V/240V

unit = above : N · m / below : kgfcm

Model Motor/ Gearhead	Ratio Speed(rpm)	3	3,6	5	6	7,5	9	10	12,5	15	18	20	25	30	36	40	50	60	75	90	100	120	150	180	200	
		K9R□120F□-D K9P□BU, BUF	1200	200V/220V/230V 240V 50Hz	1,94 19,4	2,33 23,3	3,24 32,4	3,89 38,9	4,86 48,6	5,83 58,3	6,48 64,8	7,29 72,9	8,75 87,5	10,50 105,0	11,66 116,6	13,12 131,2	15,75 157,5	18,90 189,0	21,00 210,0	26,24 262,4	30 300	30 300	30 300	30 300	30 300	30 300
200V/220V 230V 60Hz	1,90 19,0			2,27 22,7	3,16 31,6	3,79 37,9	4,74 47,4	5,69 56,9	6,32 63,2	7,11 71,1	8,53 85,3	10,24 102,4	11,37 113,7	12,79 127,9	15,35 153,5	18,42 184,2	20,47 204,7	25,59 255,9	30 300	30 300	30 300	30 300	30 300	30 300	30 300	30 300
90	200V/220V/230V 240V 50Hz		0,66 6,6	0,79 7,9	1,09 10,9	1,31 13,1	1,64 16,4	1,97 19,7	2,19 21,9	2,46 24,6	2,95 29,5	3,54 35,4	3,94 39,4	4,43 44,3	5,31 53,1	6,38 63,8	7,09 70,9	8,86 88,6	10,63 106,3	11,96 119,6	14,35 143,5	15,94 159,4	19,13 191,3	23,91 239,1	28,70 287,0	30 300
	200V/220V 230V 60Hz		0,70 7,0	0,85 8,5	1,17 11,7	1,41 14,1	1,76 17,6	2,11 21,1	2,35 23,5	2,64 26,4	3,17 31,7	3,81 38,1	4,23 42,3	4,76 47,6	5,71 57,1	6,85 68,5	7,61 76,1	9,51 95,1	11,42 114,2	12,84 128,4	15,41 154,1	17,12 171,2	20,55 205,5	25,69 256,9	30 300	30 300

- * Gearhead and decimal gearhead are sold separately.
- * The code in □ of gearhead model is for gear ratio.
- * ■ color indicates that the output shaft of the geared motor rotates in the same direction as the output shaft of the motor. Others indicate rotation in the opposite direction.
- * If you are to have less ratio than the ratio in the table, you can install the decimal gearhead, which has one tenth of the ratio, between the gearhead and the motor. In this case, the permissible torque is 30N · m/300kgfcm.
- * RPM is based on motor's synchronous rpm (50HZ:1500rpm, 60HZ:1800rpm) and calculated by dividing gear ratio. Actual rpm is 2~20% less than indicating rpm according to load size.

CONNECTION DIAGRAMS

Connect Cr circuit for absorbing surge voltage as connection diagram to protect contact point.
 $R_o = 5 - 200\Omega$
 $C_o = 0,1 \sim 0,2\mu F \ 200WV(400WV)$

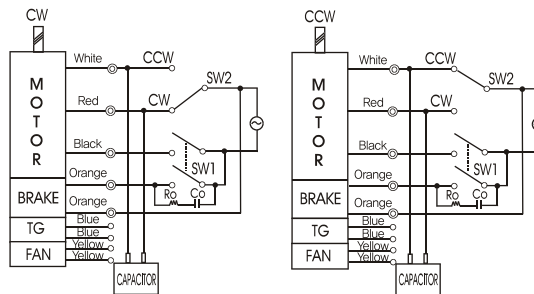

DIMENSION TABLE

PART No.	M	Application Model
01	236	50Hz
02	216	60Hz

※The direction of motor rotation is as viewed from the front shaft end of the motor

GEARHEADS

DIMENSIONS

K9P□B



K9P□BF, BUF



K9P□BU



DECIMAL GEARHEAD

K9P10BX

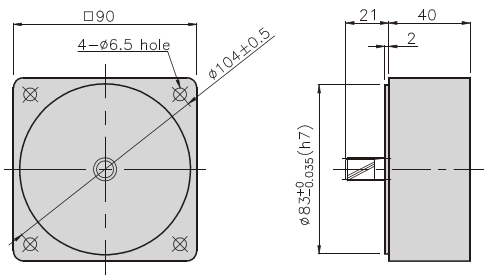

GEARHEAD

K9P□B

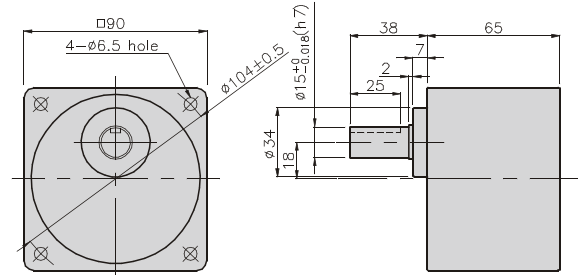

GEARHEAD

K9P□BF

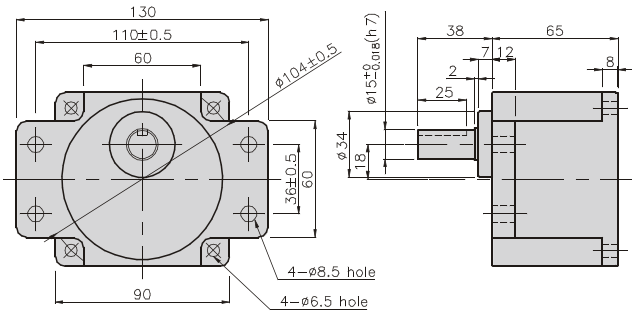

GEARHEAD

K9P□BU

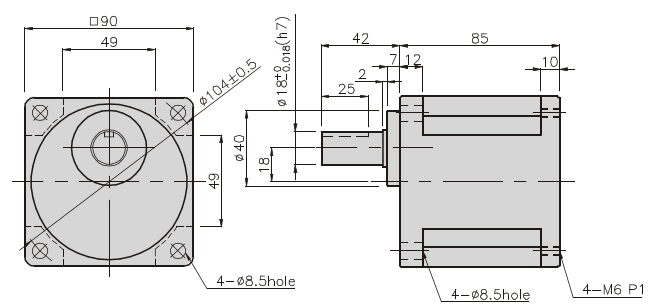

GEARHEAD

K9P□BUF

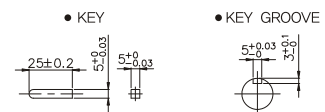
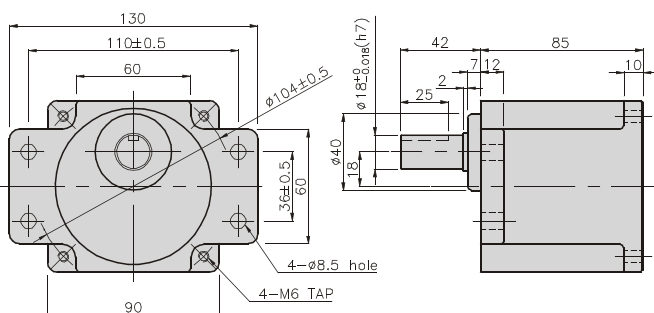

GEARHEADS

DIMENSIONS

K9RP120F□-D + K9P□B



K9RP120F□-D + K9P□BF, BUF



K9RP120F□-D + K9P□BU



K9RP120F□-D + K9P□B

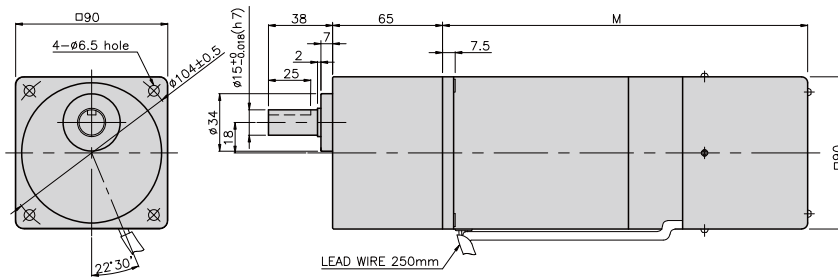

WEIGHT

PART	WEIGHT(kg)
MOTOR	3,54
DECIMAL GEAR HEAD	0,62

DIMENSION TABLE

PART No.	M	Application Model
01	155	50Hz
02	135	60Hz

DIMENSION TABLE

PART No.	L	Application Model	Mounting BOLT
01	65	K9P3~200B	M6 P1,0 X 95
02	40	K9P10BX	M6 P1,0 X 140

K9RP120F□-D + K9P□BF

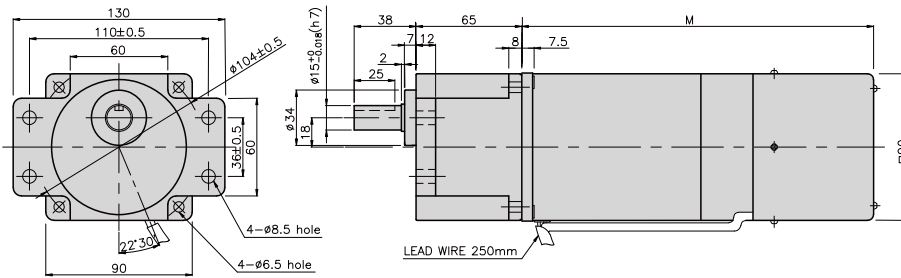

WEIGHT

PART	WEIGHT(kg)
K9P3~10B	1,22
K9P12,5~20B	1,32
K9P25~60B	1,42
K9P75~200B	1,45

DIMENSION TABLE

PART No.	L	Application Model	Mounting BOLT
01	65	K9P3~200BF	M6 P1,0 X 25
02	40	K9P10BX	M6 P1,0 X 65

WEIGHT

PART	WEIGHT(kg)
K9P3~10BF	1,22
K9P12,5~20BF	1,30
K9P25~60BF	1,42
K9P75~200BF	1,44

DIMENSION TABLE

PART No.	L	Application Model	Mounting BOLT
01	85	K9P3~200BU	M6 P1,0 X 20
02	40	K9P10BX	M6 P1,0 X 60

WEIGHT

PART	WEIGHT(kg)
K9P3~10BU	1,44
K9P12,5~20BU	1,55
K9P25~60BU	1,69
K9P75~200BU	1,74

DIMENSION TABLE

PART No.	L	Application Model	Mounting BOLT
01	85	K9P3~200BUF	M6 P1,0 X 20
02	40	K9P10BX	M6 P1,0 X 65

WEIGHT

PART	WEIGHT(kg)
K9P3~10BUF	1,50
K9P12,5~20BUF	1,62
K9P25~60BUF	1,76
K9P75~200BUF	1,82

K9RP120F□-D + K9P□BUF

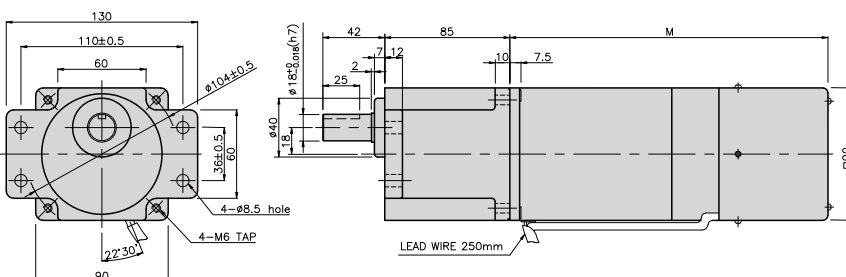

SPEED CONTROL & BRAKE MOTOR

180W

□90mm

K9RS180F□-D

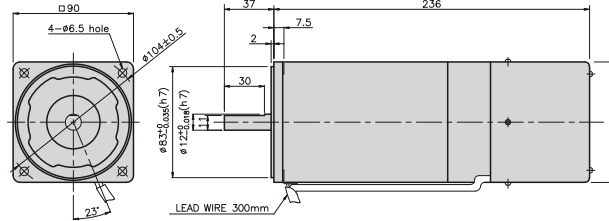

SPECIFICATIONS

180W 30 minutes rating, four poles

Model	Voltage (V)	Frequency (Hz)	Speed Range (rpm)	Permissible Torque		Start T. (N*m/Kgf*cm)	Current (A)	Condenser (μF)	Friction T. (N*m/Kgf*cm)
				1200rpm (N*m/Kgf*cm)	90rpm (N*m/Kgf*cm)				
K9R□180FJ-D	100	50	90 ~ 1400	0.88/8.8	0.33/3.3	0.5/5	5	40	1/10
		60	90 ~ 1700						
K9R□180FU-D	110	60	90 ~ 1700	1.1/11	0.38/3.8	0.58/5.8	5	40	1/10
	115								
K9R□180FL-D	200	50	90 ~ 1400	0.88/8.8	0.3/3	0.45/4.5	2.2	12	1/10
		60	90 ~ 1700			0.38/3.8			
K9R□180FC-D	220	50	90 ~ 1400	0.88/8.8	0.3/3	0.42/4.2	2.2	8	1/10
		60	90 ~ 1700			0.38/3.8			
	230	50	90 ~ 1400	0.95/9.5	0.32/3.2	0.48/4.8	2.4		
		60	90 ~ 1700			0.45/4.5			
K9R□180FD-D	240	50	90 ~ 1400	0.95/9.5	0.32/3.2	0.55/5.5	2	8	1/10

* □ : SHAFT SHAPE (S : STRAIGHT, G : PINION)

RATED TORQUE OF GEARHEAD

● Single-phase 100V/115V

unit = above : N · m / below : kgfcm

Model	Ratio	Speed(rpm)																									
		3	3.6	5	6	7.5	9	10	12.5	15	18	20	25	30	36	40	50	60	75	90	100	120	150	180	200		
K9R□180F□-D K9P□BU, BUF	1200	100V 50/60HZ	2.14	2.57	3.56	4.28	5.35	6.42	7.13	8.02	9.62	11.55	12.83	14.43	17.32	20.79	23.09	28.87	30	30	30	30	30	30	30	30	30
		110V/115V 60HZ	2.67	3.21	4.46	5.35	6.68	8.02	8.91	10.02	12.03	14.43	16.04	18.04	21.65	25.98	28.87	30	30	30	30	30	30	30	30	30	30
	90	100V 50/60HZ	0.80	0.96	1.34	1.60	2.00	2.41	2.67	3.01	3.61	4.33	4.81	5.41	6.50	7.79	8.66	10.83	12.99	14.61	17.54	19.49	23.38	29.23	30	30	30
		110V/115V 60HZ	0.92	1.11	1.54	1.85	2.31	2.77	3.08	3.46	4.16	4.99	5.54	6.23	7.48	8.98	9.97	12.47	14.96	16.83	20.19	22.44	26.93	30	30	30	30

● Single-phase 200V/240V

unit = above : N · m / below : kgfcm

Model	Ratio	Speed(rpm)																									
		3	3.6	5	6	7.5	9	10	12.5	15	18	20	25	30	36	40	50	60	75	90	100	120	150	180	200		
K9R□180F□-D K9P□BU, BUF	1200	200V/220V 50Hz/60Hz	2.14	2.57	3.56	4.28	5.35	6.42	7.13	8.02	9.62	11.55	12.83	14.43	17.32	20.79	23.09	28.87	30	30	30	30	30	30	30	30	30
		230V/50Hz/60Hz 240V/50Hz	2.31	2.77	3.85	4.62	5.77	6.93	7.70	8.66	10.39	12.47	13.85	15.58	18.70	22.44	24.93	30	30	30	30	30	30	30	30	30	30
	90	200V/220V 50Hz/60Hz	0.73	0.87	1.22	1.46	1.82	2.19	2.43	2.73	3.28	3.94	4.37	4.92	5.90	7.09	7.87	9.84	11.81	13.29	15.94	17.71	21.26	26.57	30	30	30
		230V/50Hz/60Hz 240V/50Hz	0.78	0.93	1.30	1.56	1.94	2.33	2.59	2.92	3.50	4.20	4.67	5.25	6.30	7.56	8.40	10.50	12.60	14.17	17.01	18.90	22.67	28.34	30	30	30

- * Gearhead and decimal gearhead are sold separately.
- * The code in □ of gearhead model is for gear ratio.
- * color indicates that the output shaft of the geared motor rotates in the same direction as the output shaft of the motor. Others indicate rotation in the opposite direction.
- * If you are to have less ratio than the ratio in the table, you can install the decimal gearhead, which has one tenth of the ratio, between the gearhead and the motor. In this case, the permissible torque is 30N · m/300kgfcm.
- * RPM is based on motor's synchronous rpm (50Hz:1500rpm, 60Hz:1800rpm) and calculated by dividing gear ratio. Actual rpm is 2~20% less than indicating rpm according to load size.

GEARHEADS

CONNECTION DIAGRAMS

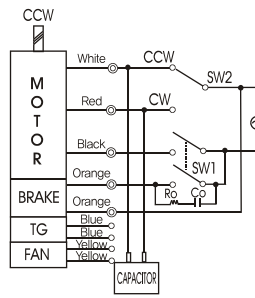
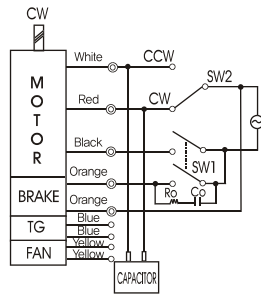

※The direction of motor rotation is as viewed from the front shaft end of the motor

DIMENSIONS

K9P□BU



K9P□BUF



DECIMAL GEARHEAD
K9P10BX

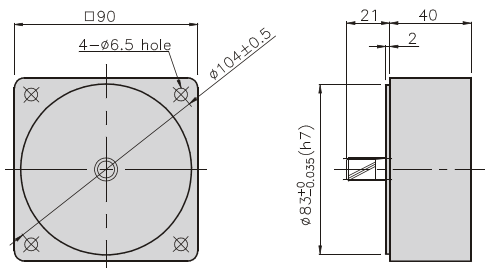

GEARHEAD
K9P□BU

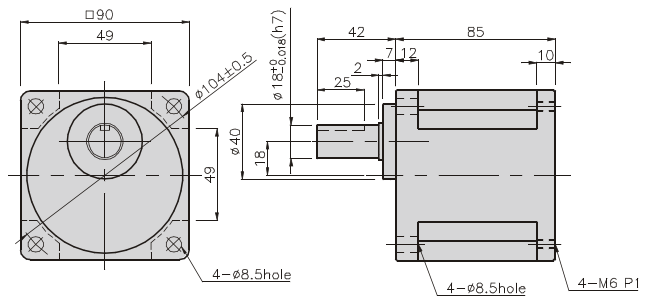

GEARHEAD
K9P□BUF

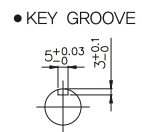
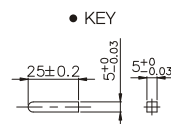
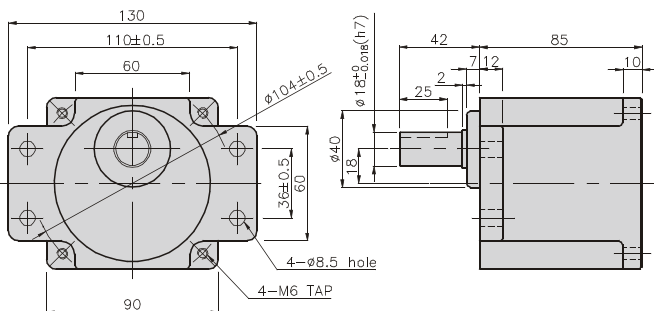

GEARHEADS

DIMENSIONS

K9RP180F□-D + K9P□BU



K9RP180F□-D + K9P□BUF



WEIGHT

PART	WEIGHT(kg)
MOTOR	4,70
DECIMAL GEAR HEAD	0,62

DIMENSION TABLE

PART No.	L	Application Model	Mounting BOLT
01	85	K9P3~200BU	M6 P1,0 X 20
02	40	K9P10BX	M6 P1,0 X 60

WEIGHT

PART	WEIGHT(kg)
K9P3~10BU	1,44
K9P12,5~20BU	1,55
K9P25~60BU	1,69
K9P75~200BU	1,74

DIMENSION TABLE

PART No.	L	Application Model	Mounting BOLT
01	85	K9P3~200BUF	M6 P1,0 X 20
02	40	K9P10BX	M6 P1,0 X 65

WEIGHT

PART	WEIGHT(kg)
K9P3~10BUF	1,50
K9P12,5~20BUF	1,62
K9P25~60BUF	1,76
K9P75~200BUF	1,82

K9RP180F□-D + K9P□BU

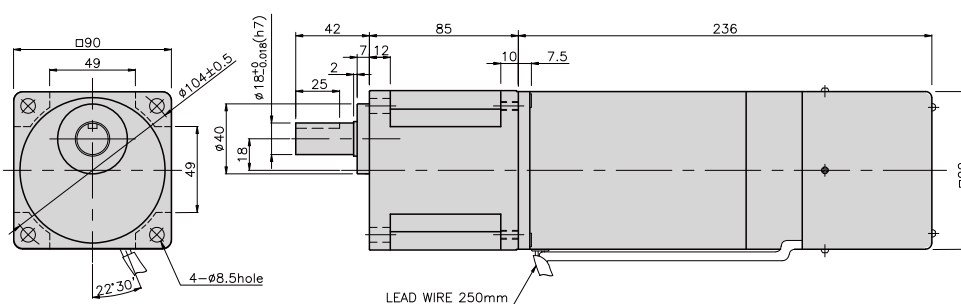

K9RP180F□-D + K9P□BUF

